



Installation instructions for part 95-6518b

APPLICATIONS

Chrysler 200 LX (with a 3.0" screen) 2015-up Jeep Cherokee Sport 2014-up Ram Trucks (without 8.4 inch touchscreen) 2013-up **95-6518B**

KIT FEATURES

- Double DIN radio provision
- **Painted matte black**
- **Note:** Modifications to factory radio cavity is required for this installation

KIT COMPONENTS

- A) Radio housing • B) Brackets

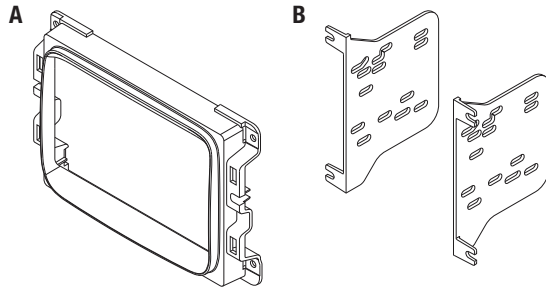

WIRING & ANTENNA CONNECTIONS (sold separately)

- Wiring Harness: • XSVI-6523-NAV
- Antenna Adapter: • 40-EU55

Table of Contents

Dash Disassembly

- Chrysler 200 LX (with a 3.0" screen) 2015-up 2
- Jeep Cherokee Sport 2014-up 3-4
- Ram Trucks 2013-up 5

Kit Assembly

- Double DIN radio provision 6

TOOLS REQUIRED

- Panel removal tool • Phillips screwdriver
- 9/32 Socket removal tool

CAUTION! Metra recommends disconnecting the negative battery terminal before beginning any installation, unless the vehicle manufacturer recommends against so. Please check with your local Dealership for more information. All accessories, switches, climate controls panels, and especially air bag indicator lights must be connected before reconnecting the battery or cycling the ignition. Also, do not remove the factory radio with the key in the on position, or the vehicle running. It would be best to remove the key from the ignition and then wait a few seconds before removing the factory radio.

REV. 8/10/2015 INST95-6518B

Dash Disassembly

Chrysler 200 LX (with a 3.0" screen) 2015-up

1. Unclip the radio trim bezel from the vehicle. (Figure A)
2. Remove (4) screws securing the radio to the dash, disconnect the connectors attached, and then remove the radio.

Continue to kit assembly

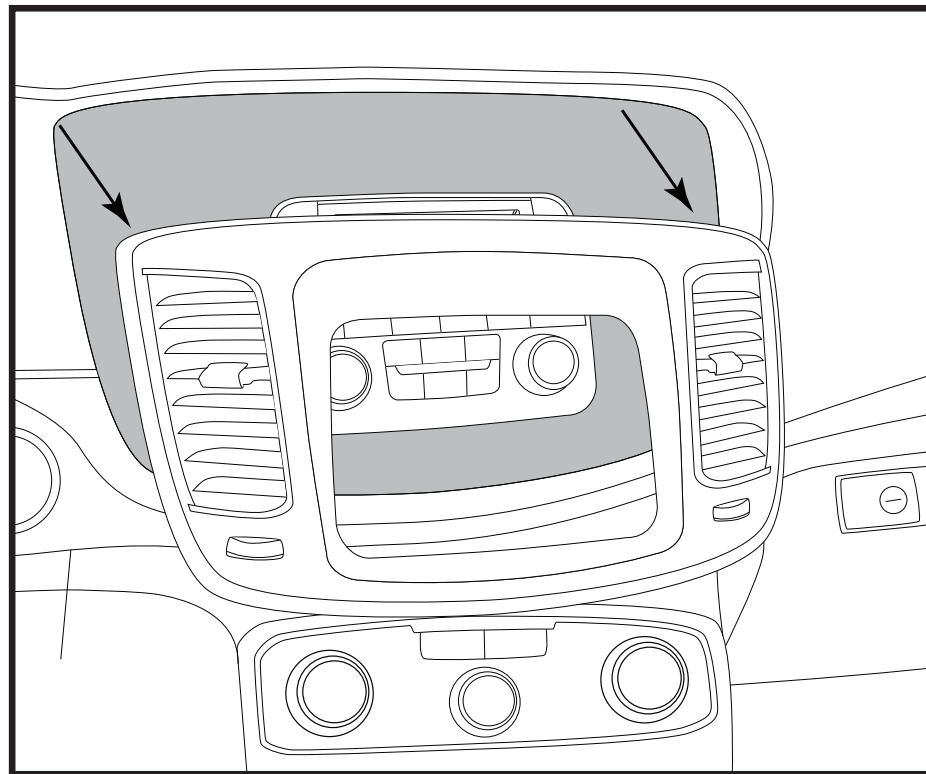

(Figure A)

Dash Disassembly

Jeep Cherokee Sport 2014-up

1. Unclip and remove the climate control panel from the vehicle and put to the side. (Figure A)
2. Remove (2) screws securing the radio trim bezel to the dash. (Figure B)
3. Unclip the radio trim bezel from the vehicle. (Figure C)
4. Remove (4) screws securing the radio to the dash, disconnect the connectors attached, and then remove the radio.
Continue on next page

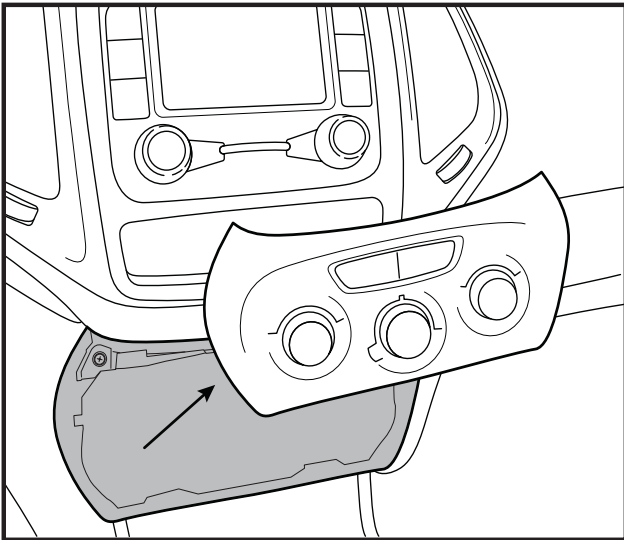

(Figure A)

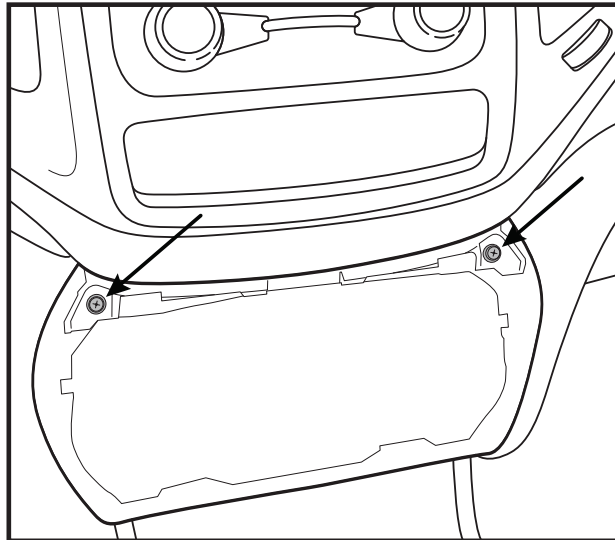

(Figure B)

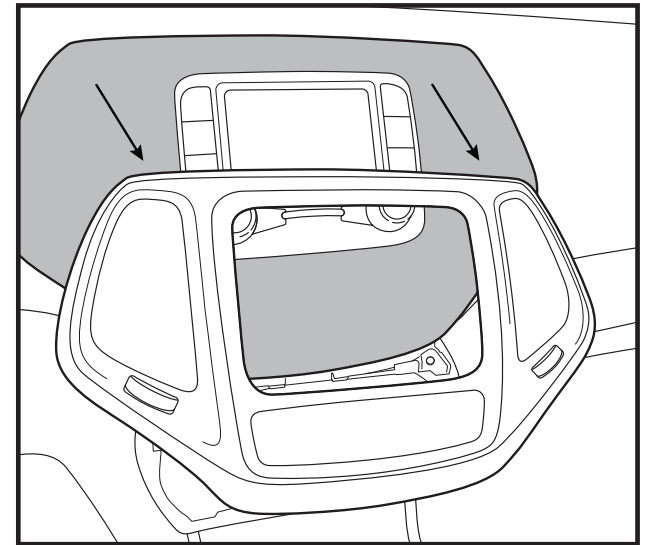

(Figure C)

Dash Disassembly

Jeep Cherokee Sport 2014-up (Continued)

Sub-dash modification:

1. Remove the rubber cover from inside the pocket on top of the dash, and then remove (1) screw exposed.
2. Remove (2) screws below the radio cavity. (Figure A)
3. From inside the radio cavity, remove (2) screws securing the metal, radio sub-dash bracket, and then discard. (Figure B)
4. Carefully cut the plastic from the bottom rear portion of the radio cavity, down to the metal brace. (Figure C)

Continue to kit assembly

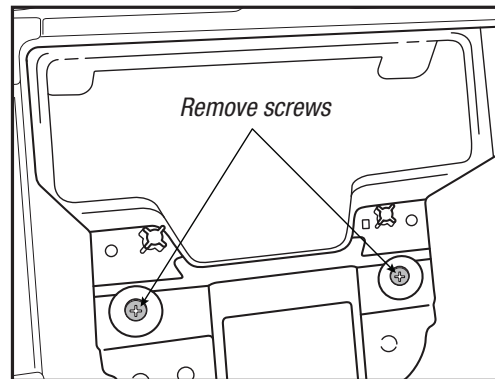

(Figure A)

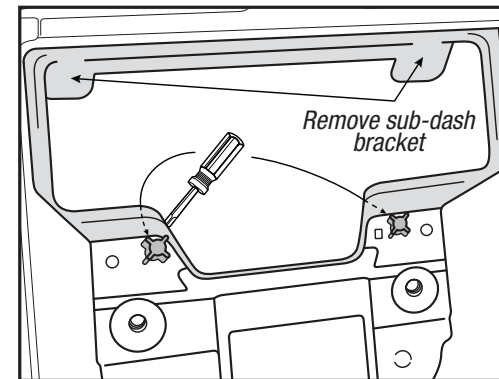

(Figure B)

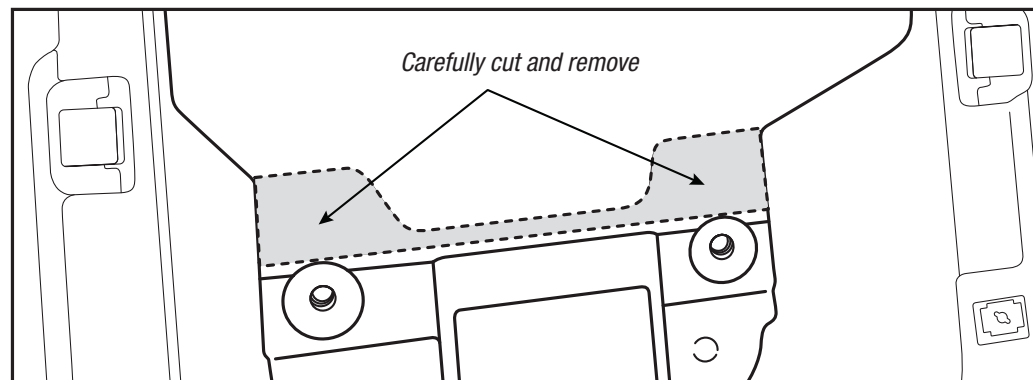

(Figure C)

Dash Disassembly

Ram (without a 8.4 inch touchscreen) 2013-up

1. Remove liner inside tray at the top center of the dash and remove (2) torx screws. (Figure A)
2. Unsnap and remove radio panel. (Figure B)
3. Remove four screws and remove radio. (Figure C)
4. The factory rear support will need to be cut or removed to allow space for a new radio. The bottom section can be removed with two cuts at the bottom corners. (Figure D)

Continue to kit assembly

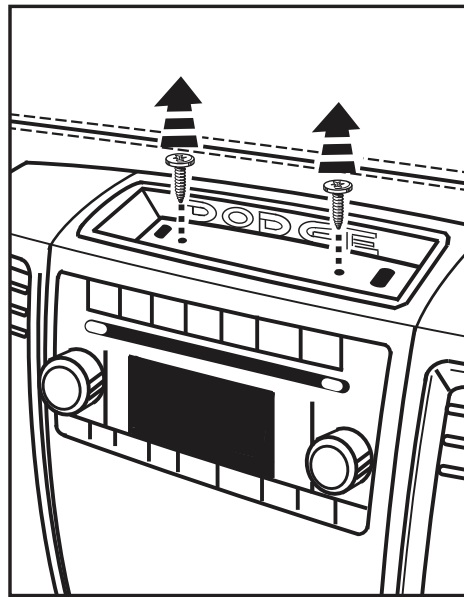

(Figure A)

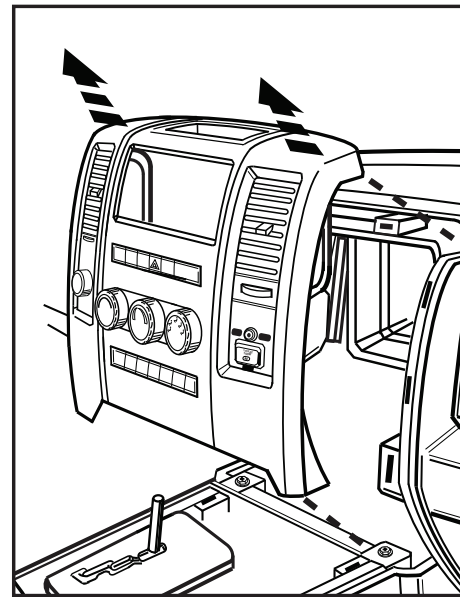

(Figure B)

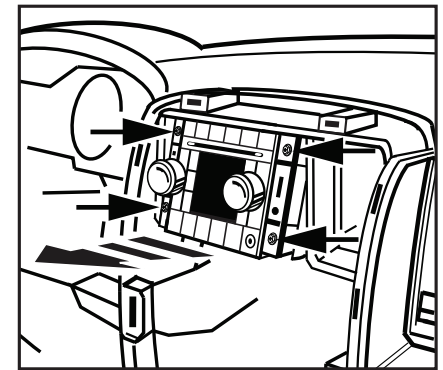

(Figure C)

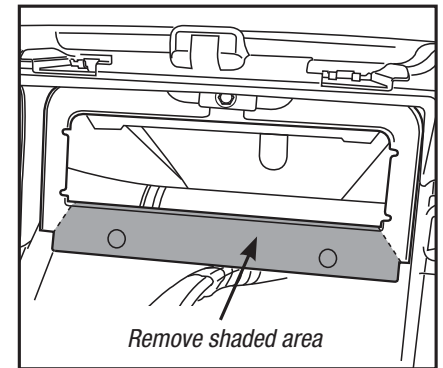

(Figure D)

Kit Assembly

Double DIN radio provision

Note: For proper orientation, the locating tabs on the Radio Housing are more to the top of the kit than bottom. (Figure A)

1. Rotate the brackets into the radio housing. (Figure B)
2. Slide the radio into the bracket/radio housing assembly and secure using the screws supplied with the radio. (Figure C)
3. Locate the factory wiring harness and antenna plug in the dash. Metra recommends using the proper mating adapters from Metra and/or AXXESS.
4. Reassemble the dash in reverse order of disassembly.

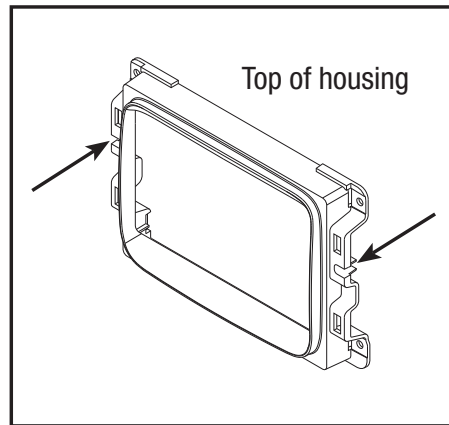

(Figure A)

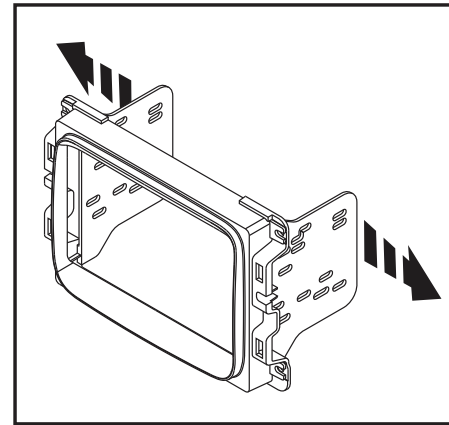

(Figure B)

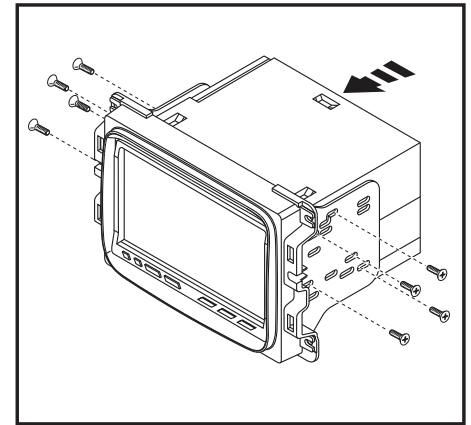

(Figure C)



Installation instructions for part 95-6518b



IMPORTANT

If you are having difficulties with the installation of this product, please call our Tech Support line at **1-800-253-TECH**. Before doing so, look over the instructions a second time, and make sure the installation was performed exactly as the instructions are stated. Please have the vehicle apart and ready to perform troubleshooting steps before calling.



KNOWLEDGE IS POWER

Enhance your installation and fabrication skills by enrolling in the most recognized and respected mobile electronics school in our industry. Log onto www.installerinstitute.com or call 800-354-6782 for more information and take steps toward a better tomorrow.



Metra recommends MECP certified technicians

REV. 8/10/2015 INST95-6518B