

15-7687052	TWIN 16V BLOCK			Rear roof antenna	
	AM/FM	GSM		O.E. SUPPLY	
Connector*	AM/FM = HC97F (RAKU 2 F)	GSM = FME F	Ext. cable	GSM (L = 5 mt Z = 50 Ω C = 101 pF/m)	
Power Supply	AM/FM = 12V / 12V Phantom	VSWR	GSM TX < 1,5:1 RX < 2:1		
Frequency	AM = 0,15 ÷ 1,71 MHz	FM = 87,5 ÷ 108 MHz	GSM = 890 ÷ 960 / 1710 ÷ 1880 MHz	AMP = 824 ÷ 894 MHz	PCS = 1850 ÷ 1990 MHz
Gain	GSM = 2.15 dBi	Consumption	AM/FM = 60 mA max	Max Power	GSM = 8W
Mounting	Coachwork drilling	OE: square 15x15 mm, r: 2 mm	AFT: hole Ø 19 mm		

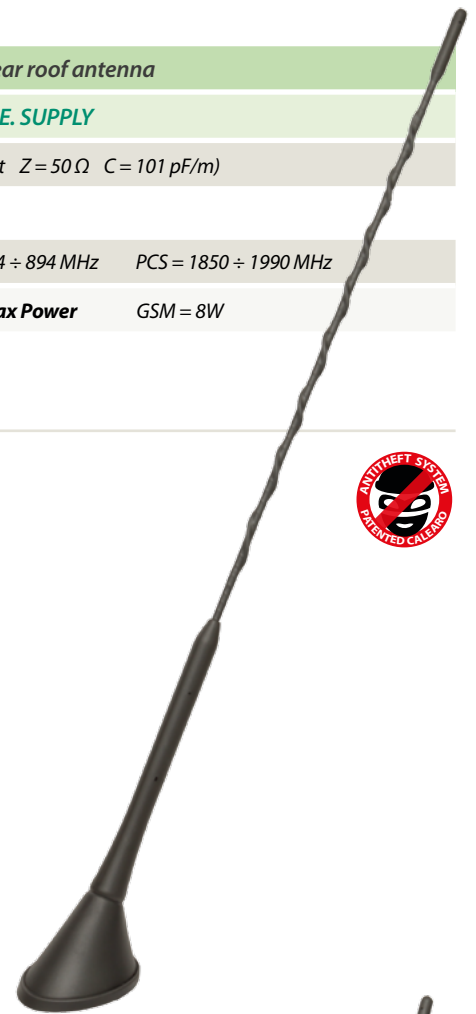

15-7680210	TRIPLEX			Rear roof antenna	
	AM - FM	GSM	GPS	O.E. SUPPLY	
Connector*	AM/FM = HC97F (RAKU 2 F)	GSM = FME F	GPS = SMB F		
Ext. cable	GSM (L = 5 mt Z = 50 Ω C = 101 pF/m)		GPS (L = 5 mt Z = 50 Ω C = 100 pF/m)		
Power Supply	AM/FM = 12V Phantom	GPS = 3 ÷ 5V Phantom	VSWR	GSM TX < 1,5:1 RX < 2:1	GPS < 2:1
Frequency	AM = 0,15 ÷ 1,71 MHz	FM = 87,5 ÷ 108 MHz	GSM = 890 ÷ 960 / 1710 ÷ 1880 MHz	GPS = 1575,42 ± 1,023 MHz	
Gain	GSM = 2.15 dBi	GPS ≥ 27 dBi	Consumption	AM/FM = 50 mA	GPS = 30 mA max
Max Power	GSM = 8W				
Mounting	Coachwork drilling	OE: square 15x15 mm, r: 2 mm	AFT: hole Ø 19 mm		

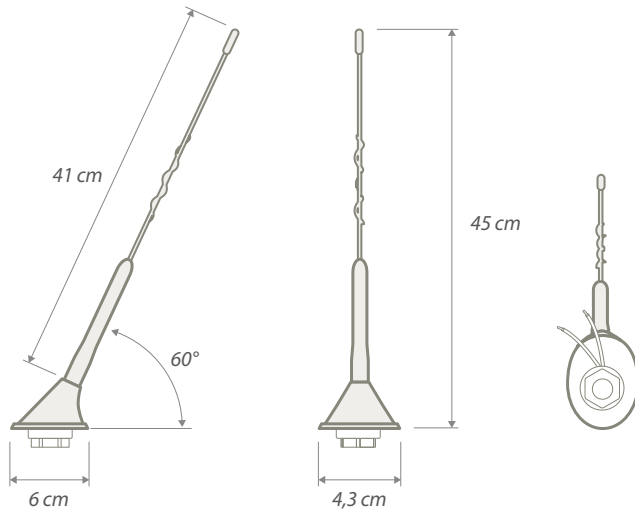