

6. Connect all required circuit points  
Place head unit on dash board

Fix it with 4 screws



7. Clip fascia plate to dash board until it snaps in.



## Installation Manual

• Fiat Ducato 06/2006 ->  
(open dash) Type 250\*

\*Not for models with SONY OEM head unit

Colour: Part-No.:  
black: 381094-29-1  
piano-black: 381094-29-2

Compatible with Double-DIN devices

### Double DIN navigation

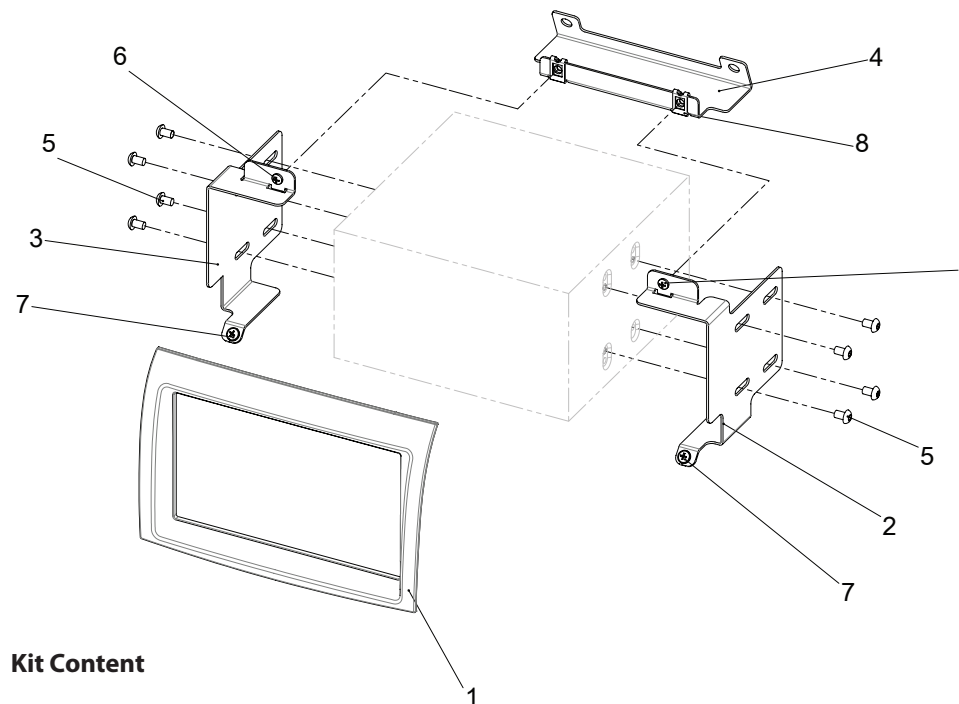

#### Kit Content

- |                            |  |
|----------------------------|--|
| (1) fascia plate           | (5) flat headed screw                        |
| (2) mounting bracket right | (6) self-tapping convex fillister head screw |
| (3) mounting bracket left  | (7) self-tapping screw with collar           |
| (4) mounting plate         | (8) speed nut                                |

*All installation work must be performed by a qualified professional installer only.  
The manufacturer / dealer is not liable for any kind of incidental or indirect damages.*



1. Remove OEM head unit and pocket

*Special tools like radio release keys may be required.*

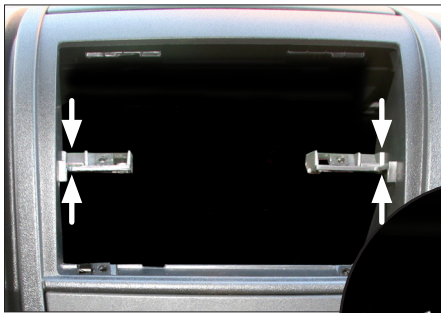

2. Cut away original brackets (marked with arrows) with appropriate tools to clear space

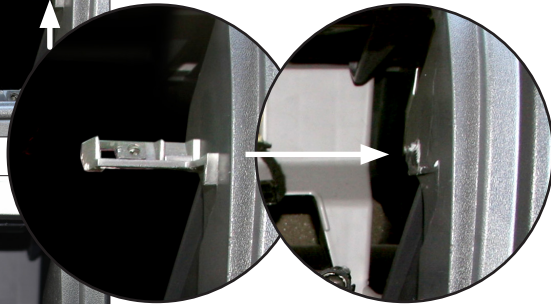

3. Ducato dashboard after cutting away brackets

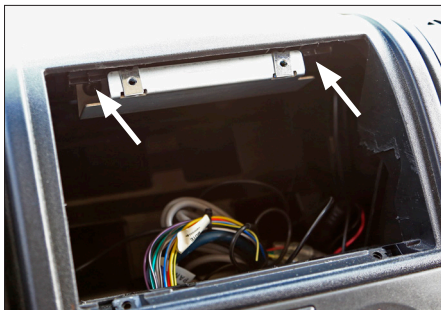

4. Assemble speed nuts on mounting plate  
Install mounting plate on top of dash board hole.

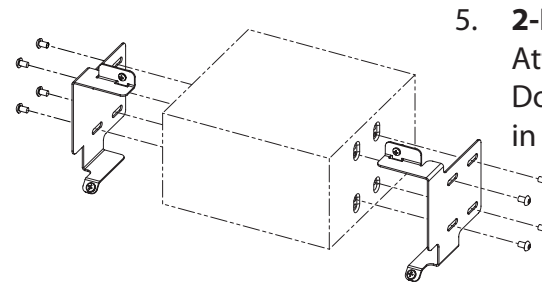
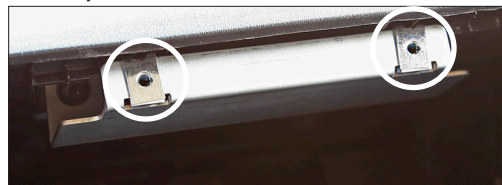

5. **2-DIN version only:**  
Attach mounting brackets to Double-DIN head unit as shown in the sample graphic

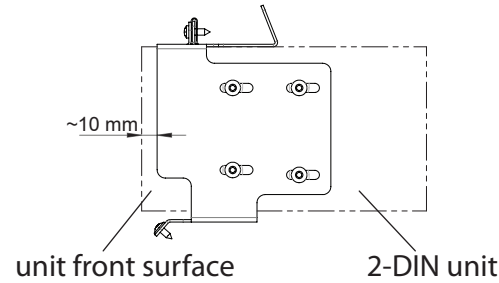

We recommend to leave app. 10 mm space to the unit front surface

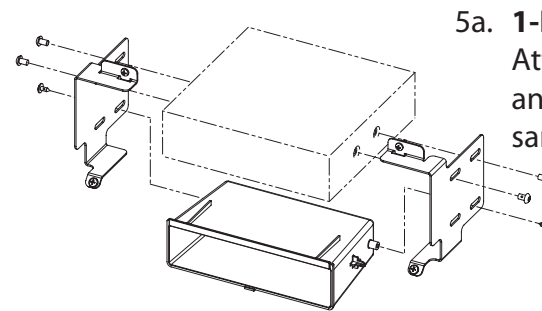

- 5a. **1-DIN version only:**  
Attach mounting brackets to pocket and 1-DIN head unit as shown in the sample graphic

pre-assembly Brackets

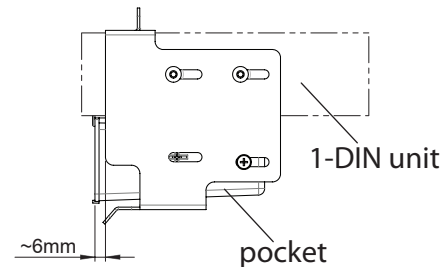

We recommend to leave app. 6 mm space to pocket

Bedienungsanleitung / Manual

Lenkradfernbedienungsadapter / Stalk Adapter

Artikelnummer / Part No.: 42sfa016

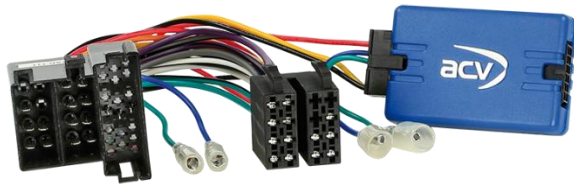

Fahrzeugkompatibilität / Vehicle Compatibility:

Fiat Ducato III 2015->



Bedienungsanleitung / Manual

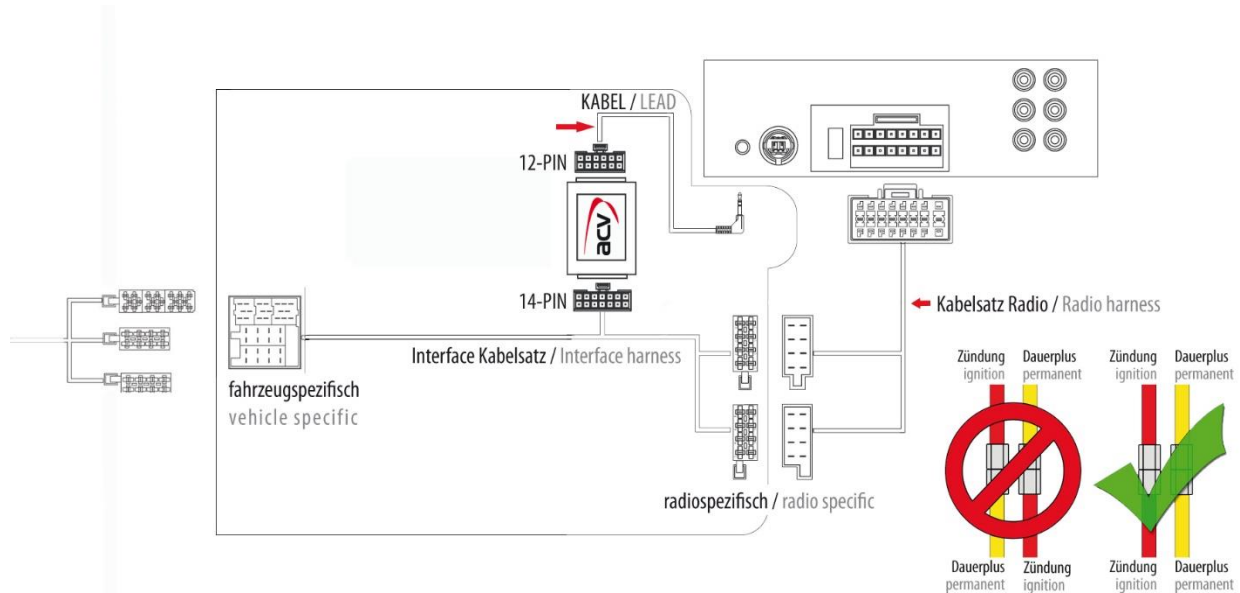

Vorgehensweise / Procedure:

1. Demontieren Sie das vorhandene Radio / Demount the present radio
2. Stecken Sie das radiospezifische Kabel/Lead (12 Pin Microfit) in das ACV Modul und verbinden Sie das andere Ende (z.B. 3,5mm Klinke) mit dem Nachrüstradio / Connect the radio specific lead (12 Pin microfit) to the ACV interface and link the other end with the retrofitting radio
3. Schließen Sie den fahrzeugspezifischen Stecker des Kabelsatzes (z.B. Quadlock) an den Fahrzeugstecker / Connect the jack of the interface harness on vehicle side to the jack of the vehicle
4. Koppeln Sie den radioseitigen Stecker des Kabelsatzes (ISO) mit der ISO Buchse des Nachrüstradios / Link the jack of the interface harness on radio side (ISO) with the ISO socket of the retrofitting radio
5. Verbinden Sie den 14-Pin Microfit Stecker mit dem ACV Modul / Connect the 14-Pin microfit jack to the ACV interface

Universelles Anschlusskabel / universal patch lead

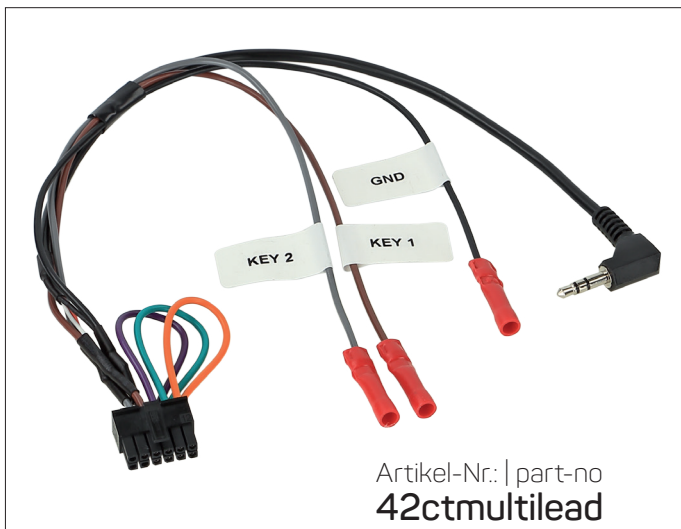

Artikel-Nr.: | part-no  
**42ctmultilead**

<b>D</b>	<b>EINBAUANLEITUNG</b>	Montage durch Fachwerkstatt erforderlich Expert Fitment Required
<b>GB</b>	<b>INSTALLATION INSTRUCTIONS</b>	Montaje sólo por el concesionario Montage par spécialiste nécessaire E' necessario in officina specializzata Especialista em montagem requerido
<b>E</b>	<b>INSTRUCCIONES DE MONTAJE</b>	Montage door vakman nodig
<b>F</b>	<b>INSTRUCTIONS DE MONTAGE</b>	Montage ved professionelt værksted påkrævet Nødvendig med montering fra fagvejværksted
<b>I</b>	<b>ISTRUZIONI DI MONTAGGIO</b>	Verkstadsmontage erfordras Asennus tarpeen merkkikorjaamossa
<b>P</b>	<b>INSTRUÇÕES DE MONTAGEM</b>	Montáž ve specializované dílně nutná A szereléshez szakmuhely kell
<b>NL</b>	<b>INBOUW-INSTRUCTIE</b>	Konieczny montaz przez warsztat specjalistyczny Montajul trebuie efectuat de un atelier de specialitate
<b>DK</b>	<b>MONTERINGSVEJLEDNING</b>	
<b>N</b>	<b>MONTERINGSVEILEDNING</b>	Technische Änderungen vorbehalten Subject to alteration without notice
<b>S</b>	<b>MONTERINGSANVISNING</b>	Reservadas modificaciones técnicas Sous réserve de modifications techniques Con riserva di apportare modifiche tecniche
<b>SF</b>	<b>ASENNUSOHJE</b>	Reservamo nos o direito a alterações técnicas Technische wijzigingen voorbehouden
<b>CZ</b>	<b>CZ NÁVOD K MONTÁŽI</b>	Med forbehold for tekniske indringer Tekniske forendringer forbeholdes
<b>H</b>	<b>BESZERELÉSI UTASÍTÁS</b>	Med reservation for tekniska ändringar Tekniset muutokset pidätetään
<b>PL</b>	<b>PL INSTRUKCJA ZABUDOWY</b>	Technické zmeny vyhrazený A változtatások technika jogát fenntartjuk
<b>RO</b>	<b>INSTRUCȚIUNI DE MONTAJ</b>	Zmiany techniczne zastrzeżone Ne rezervam dreptul la modificari tehnice

Mit dem 42ctmultilead haben Sie die Möglichkeit, jegliches spezifische Lenkradfernbedienungsanschlusskabel, im folgenden „lead“ genannt, zu konfigurieren.

Ausnahmen sind hier leads für Radios von BECKER, BLAUPUNKT oder auch PARROT (Asteroid), welche spezifisch bestellt werden müssen: (42ctbeckerlead / 42ctasteroidlead).

BLAUPUNKT muss unterschieden werden: Herstellung bis 2010 (42ctblaupunktlead), Herstellung nach 2010 je nach Gerät mit dem 42ctmultilead konfigurieren (Klinke oder Key1/Key2 und Massekabel, Konfiguration der Brücken wie bei China-Headunits).

With a 42ctmultilead you can configure any specific lead with one special cable harness! Exceptions are BECKER, BLAUPUNKT or PARROT (Asteroid), where specific leads are used. (42ctbeckerlead / 42ctasteroidlead).

BLAUPUNKT has to be differentiated between models before 2010 (42ctblaupunktlead) or after 2010 where you can configure the device with a 42ctmultilead (3,5mm jack or key1/key2 with Ground).

Bitte beachten Sie, das die spezifischen „Leads“ bzw. „Radioanschlusskabel Lenkradfernbedienung“ nur Daten bzw. geringe elektrische Spannungsänderungen übertragen. Diese Leitungen dürfen keinesfalls mit dem 12V-Stromnetz verbunden werden, dies würde die Interfaces zerstören!

Please note that the specific "leads" or "stalk harness cable" are only designed to transfer data respectively low voltage changes. These harnesses must not be connected to the 12V power supply, this would harm the interface and most likely destroy it!

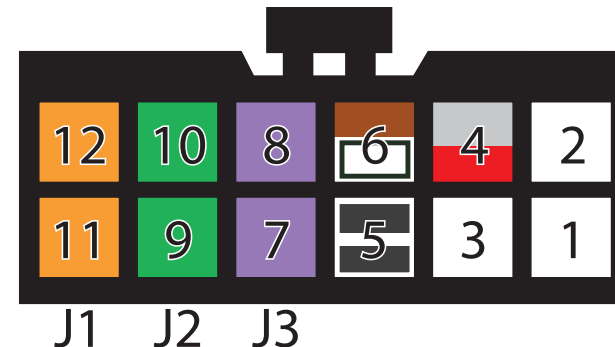

Konfigurationsanweisung / Configuration Assignments  
(1= Link made, 0= No Link)

J1	J2	J3	Systeme / Systems	Anschluss / Connector
1	0	0	JCV	Klinke/Jack/Key1
1	1	1	Blaupunkt	Key1/Key2/GND/Klinke/Jack
1	1	0	Clarion	Klinke/Jack
0	0	1	KENWOOD	Key1
1	0	1	ALPINE	Klinke/Jack
0	1	1	Panasonic	Key1
1	1	1	Sony/Pioneer	Klinke/Jack
1 (Pin12)	1 (Pin10)	0	ZENEC	Key1
1	1	1	Chinese Learning Brands	Key1/Key2/GND

Pin 1 Beschreibung / Description

Pin 1	Beschreibung / Description
1	nicht belegt / reserved
2	nicht belegt / reserved
3	nicht belegt / reserved
4	Analog 2 Swc
5	GND Swc
6	Analog 1 Swc
7	Link J3
8	Link J3
9	Link J2
10	Link J2
11	Link J1
12	Link J1

ALPINE



KENWOOD

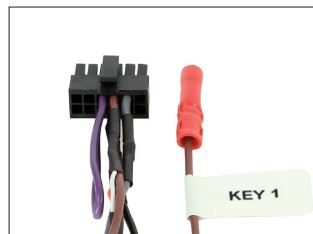

PIONEER/SONY



JVC

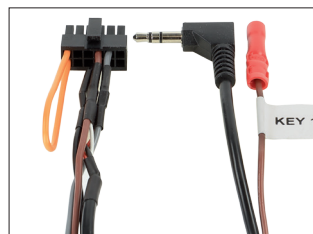

CLARION

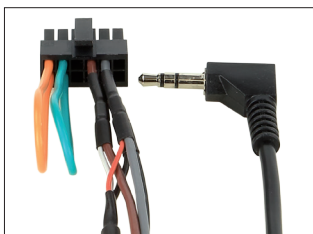

CHINA HEADUNITS

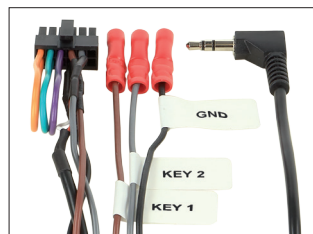

ZENEC

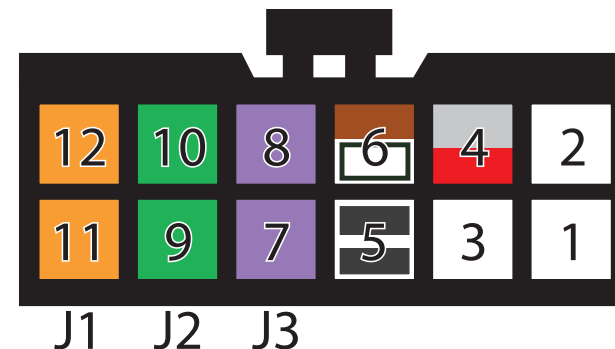
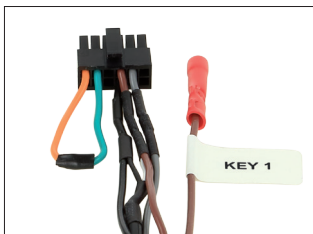

Beispiel / Example ZENEC

Entfernen Sie Brücke J3. Trennen Sie Brücke J1 und J2 mittig und löten P12 (orange) und P10 (grün) zusammen. Bitte isolieren Sie die Lötstelle fachmännisch. Verbinden Sie das Kabel (Key1) mit dem dazugehörigen Kabel des Radios (siehe Installationsanleitung des Herstellers ZENEC).

Please remove link J3. Cut the orange (J1) and green (J2) link, then solder top row together (P12 and P10) and insulate. Use the Wire connector to radio.

Beispiel / Example ALPINE

Entfernen Sie die Brücke J2 (grün) und nutzen Sie den Klinkenstecker zur Verbindung mit der dazugehörigen Klinkenbuchse der ALPINE Headunit (siehe Installationsanleitung des Herstellers ALPINE).

Please remove link J2 (green) then connect the jack connector into the jack socket of the ALPINE head unit.

Beispiel / Example KENWOOD

Entfernen Sie die Brücken J1 (orange) und J2 (grün). Schließen Sie das Kabel (Key1) an das dazugehörige Anschlusskabel der KENWOOD Headunit (siehe Installationsanleitung des Herstellers KENWOOD)

Please remove link J1 (orange) and J2 (green). Then connect the wire (Key1) to the proper wire of the KENWOOD head unit.